

MERITOR®

an ArvinMeritor brand

Technical Bulletin

Procedures and Intervals to Inspect the Wheel Ends and Tighten the Spindle Nuts on Meritor TL Series Trailer Axles with Unitized Wheel Ends

Hazard Alert Messages

Read and observe all Warning and Caution hazard alert messages in this publication. They provide information that can help prevent serious personal injury, damage to components, or both.

WARNING

To prevent serious eye injury, always wear safe eye protection when you perform vehicle maintenance or service.

Park the vehicle on a level surface. Block the wheels to prevent the vehicle from moving. Support the vehicle with safety stands. Do not work under a vehicle supported only by jacks. Jacks can slip and fall over. Serious personal injury and damage to components can result.

ASBESTOS AND NON-ASBESTOS FIBERS WARNING

Some brake linings contain asbestos fibers, a cancer and lung disease hazard. Some brake linings contain non-asbestos fibers, whose long-term effects to health are unknown. You must use caution when you handle both asbestos and non-asbestos materials.

CAUTION

A unitized hub is permanently sealed and lubricated as an assembly. Do not attempt to remove the hub bearings, seals or lubricant. You cannot service or reinstall these components back into a unitized hub. Damage to components can result. Removal of the long-life bearings, seals or lubricants from the Meritor TL model unitized hub will void the warranty.

How to Obtain Additional Maintenance and Warranty Information for TL Series Trailer Axles with Unitized Wheel Ends

Refer to Maintenance Manual MM-0420, Trailer Axles with Unitized Wheel Ends; and Maintenance Manual 14, Trailer Axles. For warranty information, refer to publication SP-95155, Commercial Vehicle Systems Warranty. To access these publications, visit Literature on Demand at arvinmeritor.com.

How to Obtain Parts

Call ArvinMeritor's Commercial Vehicle Aftermarket at 888-725-9355. To obtain Snap-On® tool, part number TTFM932, contact www.snapon.com.

Wheel-End Inspection Intervals

Refer to Inspection Intervals in Maintenance Manual MM-0420 for guidelines. Additionally, for heavy service applications as identified in publication SP-95155, Commercial Vehicle Systems Warranty, inspect the trailer axle wheel ends when you replace the tires; reline the brakes; and at least once every two months, or at 50,000 miles (80 467 km) distance traveled, whichever comes first.

Inspect the Wheel Ends

Perform the following procedure for **each** wheel end on the trailer.

1. Wear safe eye protection.
2. Park the trailer on a level surface. Use a jack to raise the trailer until all of the trailer tires are off the ground. Place safety stands under the trailer frame or axles. Do not use a jack to support the trailer.
3. Rotate the wheel assembly to check for signs of unusual resistance or roughness from the bearing. Listen for a low-pitched grinding sound as you rotate the assembly. Use care to determine whether sounds heard are coming from the bearing and not from the brake components or dust cover.
 - If unusual resistance or noise is detected: Perform the Detailed Hub Inspection procedure contained in this bulletin.

- Grasp the tire and wheel-end assembly at the 12 and six o'clock positions. Check for vertical and horizontal movement. With your hands, apply approximately 50 lb (23 kg) of force to the assembly. You should not feel or see any looseness or movement. Figure 1.

- **If you feel or see more than 0.04-inch (1 mm) of movement at the tire circumference:** Proceed to the Quick Clamp Load procedure, which avoids removing the wheel drum assembly; or the Detailed Hub Inspection procedure, depending on the available downtime.
- **If no movement is detected:** The inspection is complete.

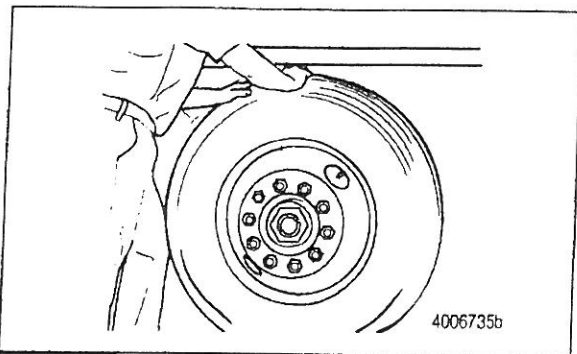

Figure 1

Quick Clamp Load

- Remove the hubcap.
- Use a screwdriver to release the stakes from the stake washer flange. Figure 2.

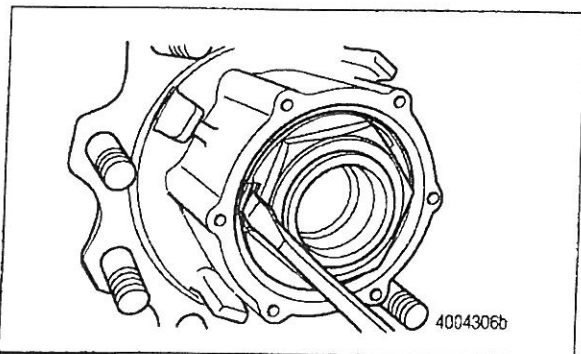

Figure 2

⚠ WARNING

You must rotate the hub **COUNTERCLOCKWISE** while you tighten the spindle nut to the specified torque. If you do not rotate the hub during the tightening procedure, the spindle nut can loosen, and the bearing may not seat correctly, which can cause the wheel to separate from the vehicle during operation. Serious personal injury and damage to components can result.

- Tighten the spindle end nut to 810-850 lb-ft (1100-1150 N•m) while rotating the wheel and hub in a **COUNTERCLOCKWISE** direction. Do not back off the nut after tightening. Re-clamp and mark the spindle nut position relative to the spindle. For future service, use the marks to show if the nut has rotated. ⚠
- Rotate the wheel assembly to check for signs of unusual resistance or roughness from the bearing. Listen for a low-pitched grinding sound as you rotate the assembly. Use care to determine whether sounds heard are coming from the bearing and not from the brake components or dust cover.
 - **If unusual resistance or noise is detected:** Perform the Detailed Hub Inspection procedure contained in this bulletin.
- Grasp the tire and wheel-end assembly at the 12 and six o'clock positions. Check for vertical and horizontal movement. With your hands, apply approximately 50 lb (23 kg) of force to the assembly. You should not feel or see any looseness or movement. Figure 1.
 - **If you feel or see more than 0.04-inch (1 mm) of movement at the tire circumference:** Perform the procedure in Thread Inspection to verify there is not a problem with the threads.
- Use a hammer and staking tool (part number AM21225831) to stake the stake washer to the nut in three positions. Bend the washer to the stake profile as shown. Figure 3 and Figure 4.
 - **If the first stake does not align with the slot on the flange nut:** Stake a previously unused section of the retaining washer outer flange into two or three slots on the flange nut face. NOTE: Stake three slots if possible.

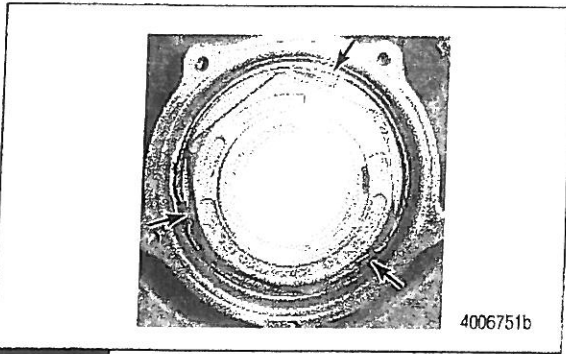

Figure 3

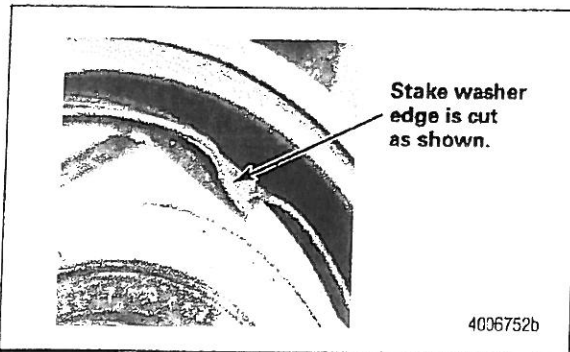

Figure 4

7. Install the hubcap with a new gasket (part number AM2208P1160). Tighten the hubcap capscrews in a crisscross pattern to 10-15 lb-ft (13-20 N-m). ①

Detailed Hub Inspection

1. Follow the wheel manufacturer's instructions to remove the tire, wheel assembly and brake drum. Figure 5.



Figure 5

2. If necessary, remove the hubcap.
 - **If this is not the first inspection:** Check the mark on the spindle nut and spindle to see if the nut has moved.
 - **If the mark has moved, then the nut was not previously tightened enough:** Clean the threads.
3. Attach the magnetic base of the dial indicator to the spindle. Touch the dial indicator stem to the hubcap mounting surface. Figure 6.

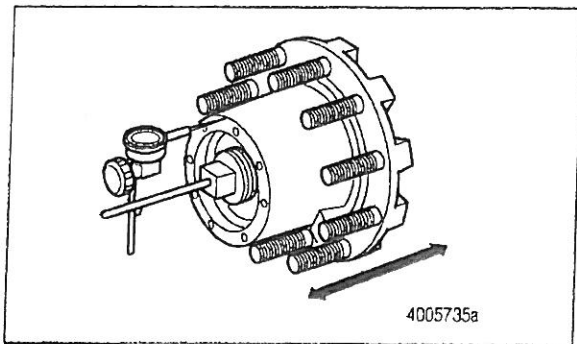

Figure 6

4. Set the dial indicator to ZERO. Do not rotate the wheel end. Place your hands at the nine and three o'clock positions.
5. Push the unitized wheel end straight IN. Note the reading. Then pull the wheel end straight OUT. Note the reading. If the total movement of the dial indicator is less than 0.003-inch (0.08 mm), perform the following steps.
 - A. Tighten the spindle nut to 810-850 lb-ft (1100-1150 N-m). Stake the stake washer to the spindle nut in three positions as shown in Figure 3. ①
 - B. Mark the nut and spindle to record the position of the nut.
 - C. Reassemble the hubcap using a new gasket (part number AM2208P1160).
 - D. Tighten the hubcap screws in a crisscross pattern to 10-15 lb-ft (13-20 N-m). Record the end play. If total movement is 0.003-inch (0.08 mm) or greater, proceed to Thread Inspection. ①

Thread Inspection

Perform the following procedure for each wheel end on the trailer with end play at the hub greater than 0.003-inch (0.08 mm) or wheel movement greater than 0.04-inch (1 mm).

1. Use a screwdriver to release the stakes from the stake washer flange. Figure 7.

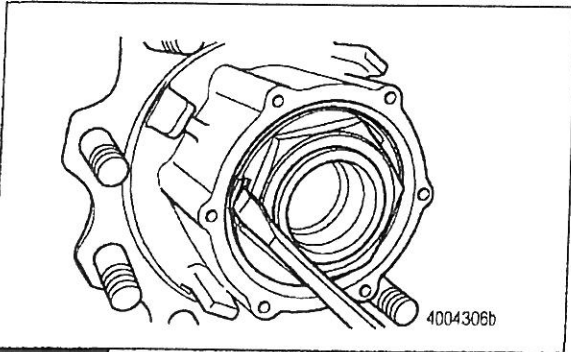

Figure 7

2. Remove the spindle nut from the spindle end. Figure 8. Check to ensure the spindle nut is free of resistance and the threads are not damaged. Fully thread the nut by hand down the entire length of the thread without the stake washer in place. Then remove the nut.

- **If the threads are damaged:** Replace the spindle nut (part number AM21225405).

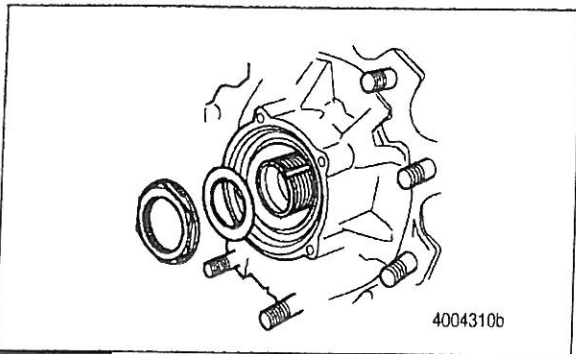

Figure 8

3. Inspect the inboard face of the stake washer for wear or an indent from the bearing contact face. Figure 9.
 - **If wear exists:** Discard the washer unless the hub is being returned.
 - **If the hub is being returned:** Also return the washer and spindle nut.

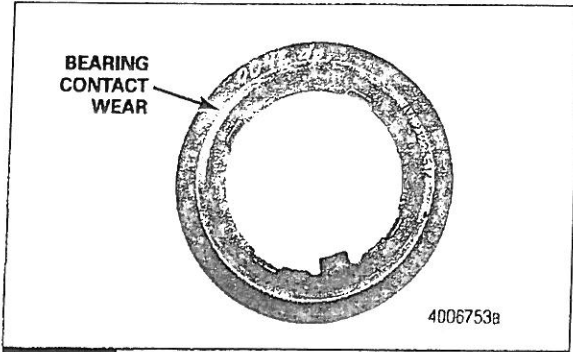

Figure 9

4. Check the spindle threads. Figure 10.
 - **If the threads are not free running, and a limit of two threads are damaged:** Repair the threads with a thread file (Snap-On® tool, part number TTFM932, or equivalent).
 - **If there are more than two threads damaged:** Replace the axle beam. Refer to Maintenance Manual 14 for the procedures.

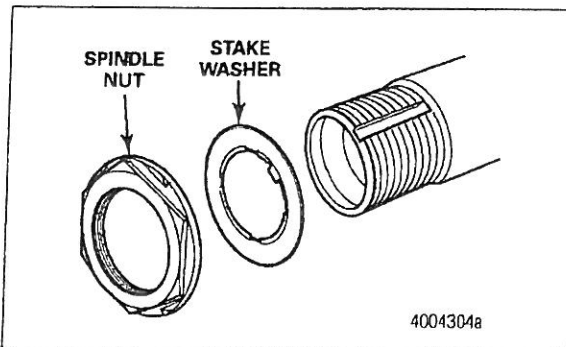

Figure 10

5. Clean the spindle threads and nut threads.
6. Install a new stake washer (part number AM21225514), or the existing washer if it is not worn or damaged, onto the spindle.
7. Install the spindle end nut (part number AM21225405) onto the spindle.

⚠ WARNING

You must rotate the hub **COUNTERCLOCKWISE** while you tighten the spindle nut to the specified torque. If you do not rotate the hub during the tightening procedure, the spindle nut can loosen, and the bearing may not seal correctly, which can cause the wheel to separate from the vehicle during operation. Serious personal injury and damage to components can result.

8. Tighten the spindle end nut to 810-850 lb-ft (1100-1150 N•m) while rotating the wheel and hub in a **COUNTERCLOCKWISE** direction. Do not back off the nut after tightening. Mark the nut location relative to the spindle. Figure 11. ①

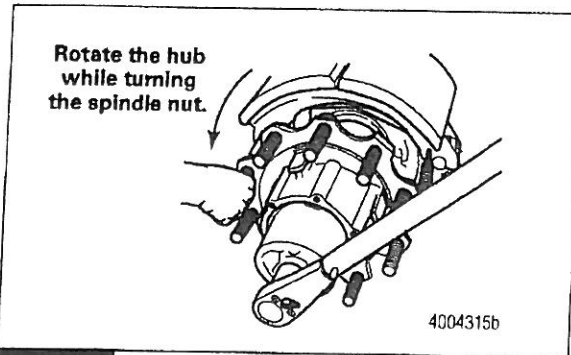

Figure 11

9. Check for wheel-end movement to ensure the wheel end rotates freely as described in the inspection procedure. Verify end play is less than 0.003-inch (0.08 mm) by following Steps 3, 4 and 5 of Detailed Hub Inspection. Record the end play in the hub inspection form.
 - If end play is greater than 0.003-inch (0.08 mm): Replace the hub. Refer to Replace the Hub for the procedures.
10. Use a hammer and staking tool (part number AM21225831) to stake the stake washer to the nut in three positions. Bend the washer to the stake profile as shown. Figure 12 and Figure 13.

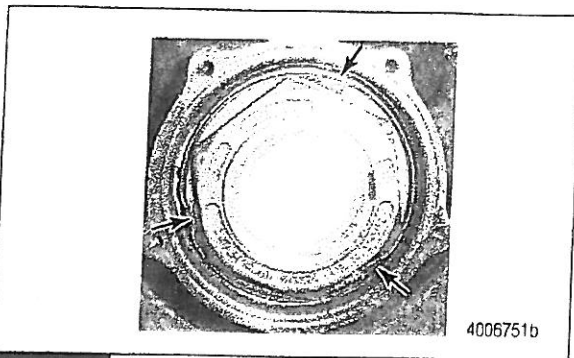

Figure 12

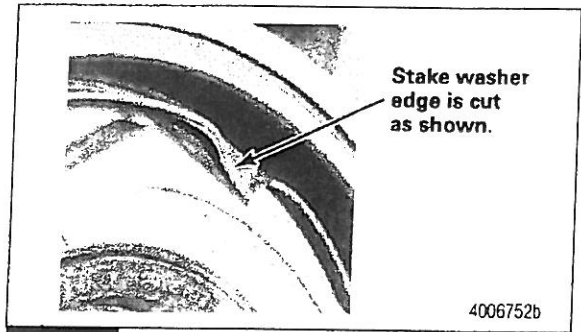

Figure 13

11. Install the hubcap with a new gasket (part number AM2208P1160). Tighten the hubcap capscrews in a crisscross pattern to 10-15 lb-ft (13-20 N•m). ①

Replace the Hub

Proceed to the steps below if you are replacing the hub and bearing assembly. Also refer to Figures 4-19 through 4-22 in Maintenance Manual MM-0420.

Contact ArvinMeritor's Commercial Vehicle Aftermarket at 888-725-9355 for the correct hub replacement part number.

NOTE: Previous versions of TL hubs may or may not have an O-ring on the inboard side of the hub. All replacement hubs will include an O-ring. This O-ring must be installed with the replacement hub regardless of previous hub arrangement.

1. Ensure the O-ring (part number AM1205Q2747) between the bearing cartridge and the spindle shoulder is inserted into the groove and in place when the hub is installed. Figure 14.

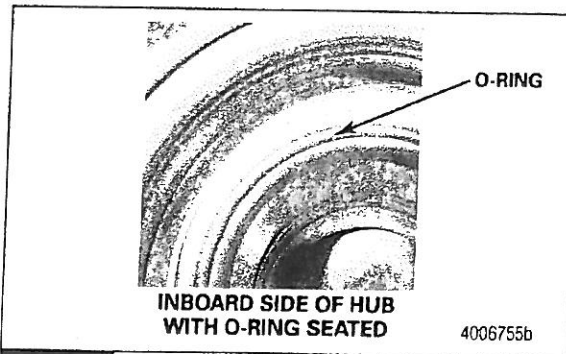

Figure 14

2. Check the spindle to ensure there is **NOT** an extra O-ring.
3. Apply an anti-seize compound (Optimol White Paste T or similar product) to the spindle before remounting the hub.
4. Complete Step 5 through Step 11 of the Thread Inspection procedure.